

FLURRY MACHINE

VARY YOUR MENU OPTIONS
WITH THIS FANTASTIC MACHINE

INDUSTRY LEADING FOOD SERVICE EQUIPMENT



The perfect option for flurry or milkshake offerings to **prepare extraordinary desserts**

FLURRY OPTION

DISPOSABLE BESPOKE SPOON

For the likes of flurrys where the customers takeaway with the spoon

MILKSHAKE OPTION

BLENDING BLADE

For the creation of flavoured milkshakes

THE **FLURRY MACHINE** MIXES & BLENDS **ADDITIONAL OPTIONS** INTO YOUR SOFT ICE CREAM SUCH AS: FLAVOURS, CHOCOLATE BITS, CRUSHED COOKIES/NUTS, FRUIT CHUNKS, CEREALS, SYRUPS IN SECONDS.

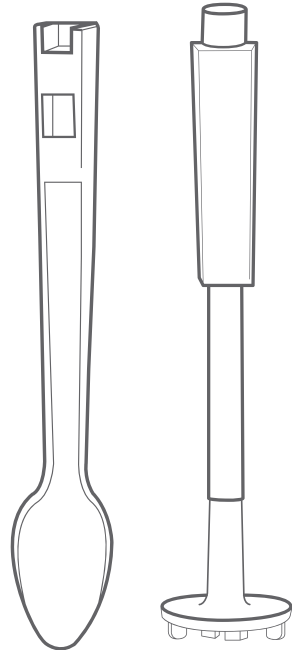

FLURRY MACHINE VARY YOUR MENU OPTIONS WITH THIS FANTASTIC MACHINE

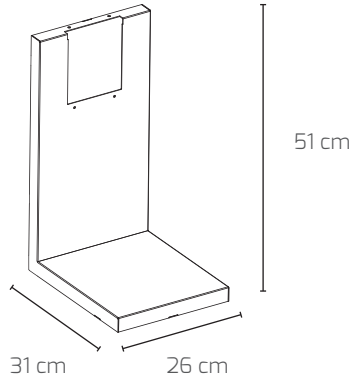
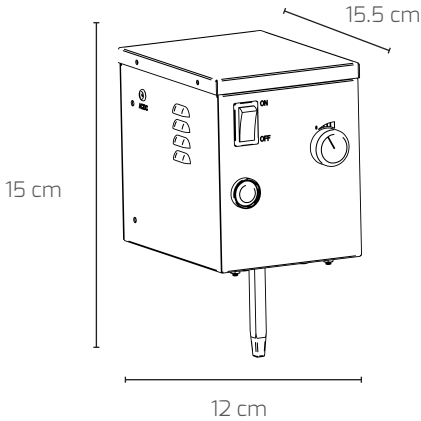

SPECIFICATIONS

| | | |
|----------------|-----------------|--|
| Colours | Black and white | |
| Materials | Stainless Steel | |
| Rotation Speed | 0-1,500 R.P.M | |

| WEIGHT | KG | KG (W/ STAND) |
|--------|-----|---------------|
| Net | 3.8 | 4.9 |

| DIMENSIONS | NET (CM) | NET (W/ STAND CM) |
|------------|----------|-------------------|
| Width | 12 | 26 |
| Depth | 15.5 | 31 |
| Height | 15 | 51 |

| ELECTRICAL | AMP | FREQUENCY |
|------------|-------|-----------|
| | 13amp | - |

STANDARDS & CERTIFICATIONS

Our flurry machine has CE marking. CE marking indicates that the machine complies with European health, safety and environmental protection legislation.

FEATURES

- A REGULATOR ENABLES CONVENIENT CONTROL OF THE BLADE VARYING ROTATION SPEED
- MACHINE BODY IS MADE OF STAINLESS STEEL
- MODERN AND SLEEK DESIGN
- COMPACT DESIGN
- EASY TO UTILIZE AND CLEAN

We also offer the special disposable plastic spoons and stainless steel blades that are used in the stirring process.